



Drying



Conveying



Dosing



Storage

ADRW 50



Technical Specifications

Model	Temp	Air flow	Regen. Blower	Heating	Power installed	Dew Point	Weight
ADRW 50	55 - 160°C	20 - 50 m3/h	5 - 15 m3/h	2,5 KW	4,21 KW	0 - 55°C	52 Kg

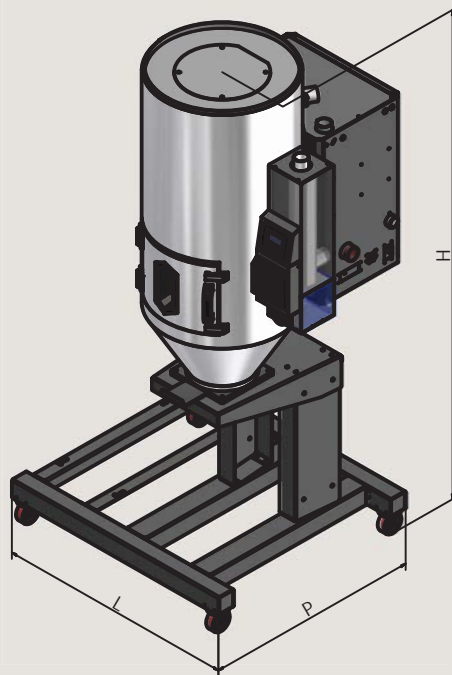

Dimensions

Hopper size	L mm	P mm	H mm
75 Liters	940	852	1670
100 Liters	940	852	1880
150 Liters	940	852	2020
AIR HOSE diameter		50	

Energy Consumption

Material	KWh/Kg	€/Kg ⁽¹⁾
ABS	0,06	0,0062
PA6	0,07	0,0079
PC	0,08	0,0087

Calculated with a Dew Point @-40 contact us for a more specific calculation
 (1) €/kWh = 0,11

Main Features

- Modulable System
- Compact and versatile
- VISNET ready
- High performance dust free dehumifying rotor driven by a step motor
- Double brush less blower (processing & regeneration) circuit with adjustable speed control
- Self adjustable air flow on the production demand
- Self adjustable Dew Point control without dew point sensor
- Close loop cooling circuit
- Compressed Air free
- MPM Material Protection Management
- SLS Safety Loading System
- Water free
- Material receipt
- Anti stress system
- Graphic high contrast display
- Network LAN RS485 ready
- Aluminium frame, PREOX
- Electrical panel complying with EC recommendations (73/23/EC and related standards), housed in a compartment isolated and including 24V control circuit switching transformer, mains switch, solid state rele
- Microprocessor control, complying with EC recommendations (89/336/EC), to provide highly accurate real-time temperature control of the operating conditions, displaying all operating parameters and any fault conditions (complete with LUT - local user terminal)
- Standard colour RAL 9006
- Integrated daily weekly timer (optional)
- Integrated feeding system (optional)
- Standard packing

